

VDH RAPID IMPACT COMPACTION

Your solid partner for soil compaction



**20+ YEARS
EXPERIENCE**
IN DEVELOPING AND
MANUFACTURING
R.I.C. MACHINES



About us

Van den Heuvel is a specialized company with extensive expertise in foundation equipment, revision projects and custom-built solutions. Our engineers develop thorough designs, while our experienced mechanics and certified welders ensure a high-quality end product. We have more than 20 years of experience in developing and manufacturing RIC machines. Our machines have been successfully used to compact gravel, sands, silts and industrial waste fills. With powerful hammers and proven performance under all conditions, our RIC units deliver reliable and efficient ground improvement.



Compacting soil at forty beats per minute

We supply one of the most powerful and efficient soil compaction systems available today. This system is designed for the rapid and precise compaction of large areas of land. It combines speed, cost-efficiency, safety and proven effectiveness. In response to market demand, multiple complete units are currently in operation, with further expansion underway.

The compaction method uses a combination of an accelerated drop weight and a compaction foot to densify sandy soils. The process involves dropping the weight onto the foot at a rate of at least 40 impacts per minute, while the foot maintains continuous contact with the ground. The repeated impacts compact the soil efficiently. An example of the equipment in use is shown in Figure 1. The version shown features a 17-ton drop weight.

BENEFITS OF OUR RIC MACHINES:

- Proven reliability and functionality
- Rugged design drawn and calculated by our own engineering department
- Much more stability and working strength thanks to cradle
- Powerful VDH hydraulic impact hammers
- Excellent performance under all circumstances
- Compliant with all safety requirements applicable
- Compaction equipment delivered with CE-certificate
- Onsite service worldwide
- Available in specific corporate colors
- Training onsite

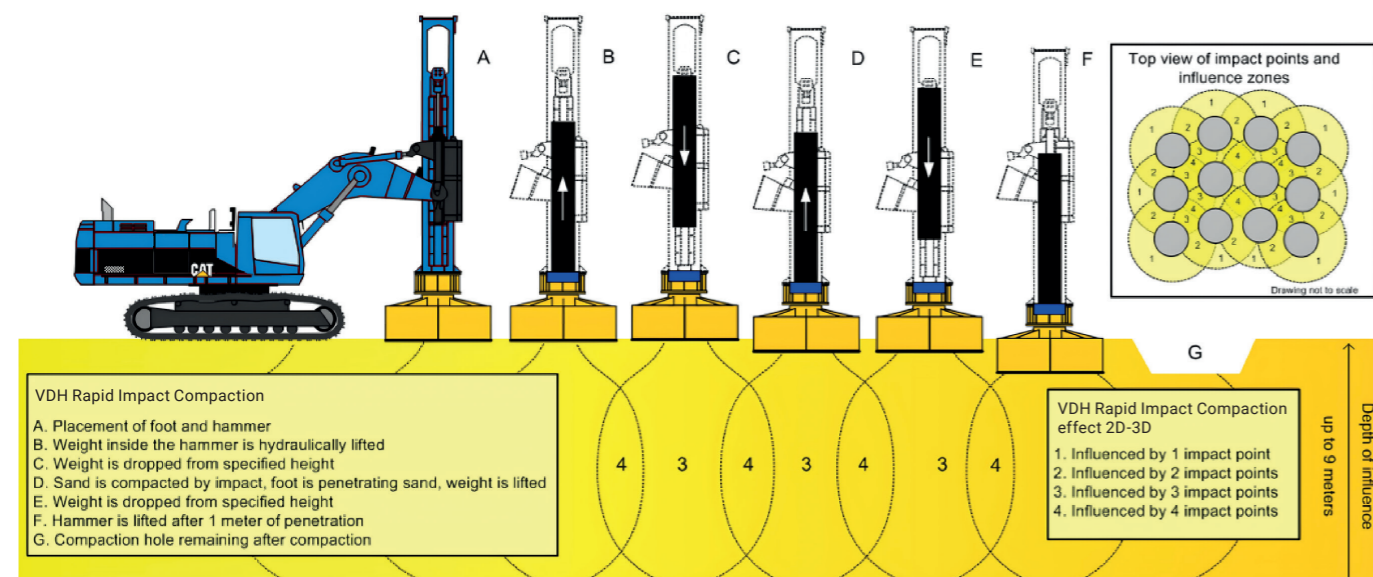

(Fig. 1) This technology is currently applied on several large-scale projects, both internationally and within the Netherlands. For these applications, we have engineered custom modifications, such as a specially designed boom for a 85-95 tons excavator. This boom supports both the frame and the hammer used in the compaction process. To enhance stability during operation, additional counterweight—up to 14 tons—is added to the machine. The total weight of the complete setup is approximately 130 tons.

Explore the configuration

Figure 2 shows the key components of our advanced compaction unit. Each component fulfills a critical role in delivering accurate and efficient ground improvement through Rapid Impact Compaction (RIC). The system is engineered to maximize energy transfer, optimize compaction depth and ensure consistent performance across varying soil conditions.

- 1 Base hammer
- 2 Hammer lift cylinder
- 3 Cradle
- 4 Monoboam
- 5 Compaction foot
- 6 Tilt cylinder

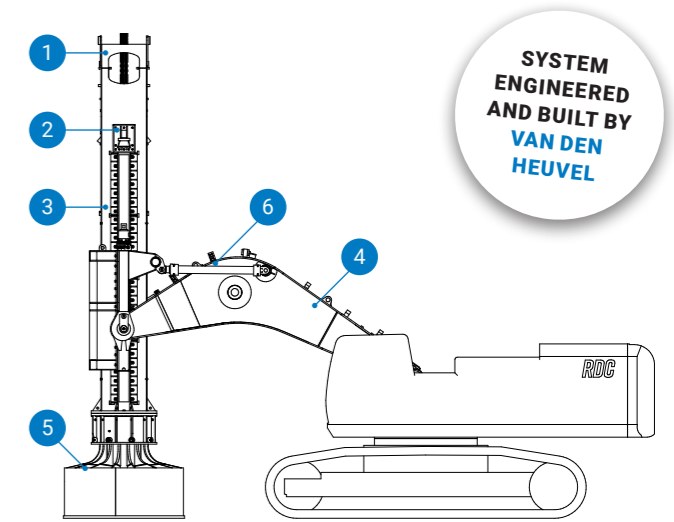

(Fig. 2)

SYSTEM ENGINEERED AND BUILT BY VAN DEN HEUVEL

	VDH-RDC-9	VDH-RDC-12	VDH-RDC-17
Machine type	50-55 tons	65-70 tons	85-95 tons
Hammer type	VDH-9-1500	VDH-12-1200	VDH-17-1200
Drop height	50-1500 mm	50-1200 mm	50-1200 mm
Blows p. min.	30-100	40-100	40-100
Max. energy	132 kNm	141 kNm	200 kNm
Drop weight	9000 kg	12000 kg	17000 kg
Total weight	16000 kg	20500 kg	25000 kg
Oil flow	328 l/min	795 l/min	795 l/min
Working pressure	260 bar	157 bar	220 bar
Theoretical power needed	142 kW	208 kW	292 kW
Drive cap type	880 mm	1080 mm	1080 mm
Compaction foot	1600 mm	1600/2000 mm	1600/2000/2400 mm

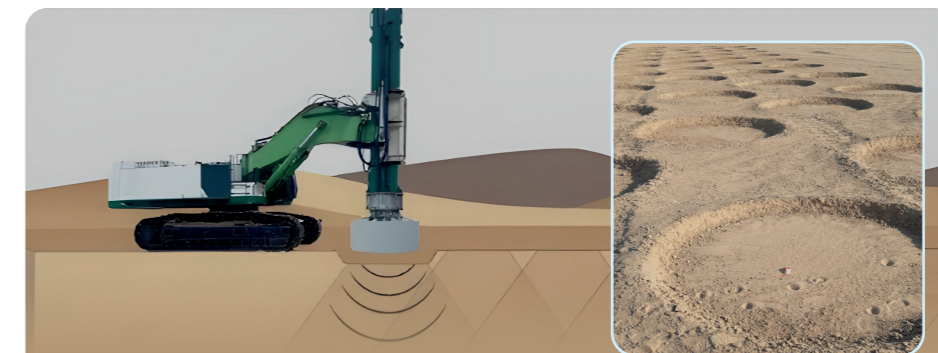

Efficient energy transfer for optimal ground improvement

The compaction unit applies high-frequency dynamic forces to the soil surface, transferring energy deep into the ground. This process densifies loose granular soils, increases bearing capacity, and reduces settlement – creating a stable foundation for future construction.

Your contactperson for VDH-RIC:

Jan Schuringa
 Accountmanager Projects
 Tel. +31 (0)6 20 862 325